



山东鑫盟制造有限公司 SYB EAST CO. LTD

HDPE, PP & Plastic Manhole machining center CNC control Horizontal boring machine

Model: SYB 2000MM

Special design to meet requirement of customer to machine holes on plastic manholes of size 600mm to 2000mm. Hole size 100mm to 1000mm.



Model SYB 2000MM



Human machine interface

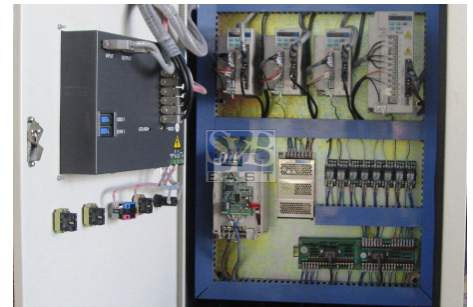

Control drives



360 degree rotating bed



Special clamp for manholes



Adjustable clamp 600 to 2000mm



Machining 100mm hole



Rotation after machining



Machining 800mm hole



800mm hole



Inserting inlet out let pipes



Plastic welding



山东鑫盟制造有限公司 SYB EAST CO. LTD

X, Y, Z and A Movements

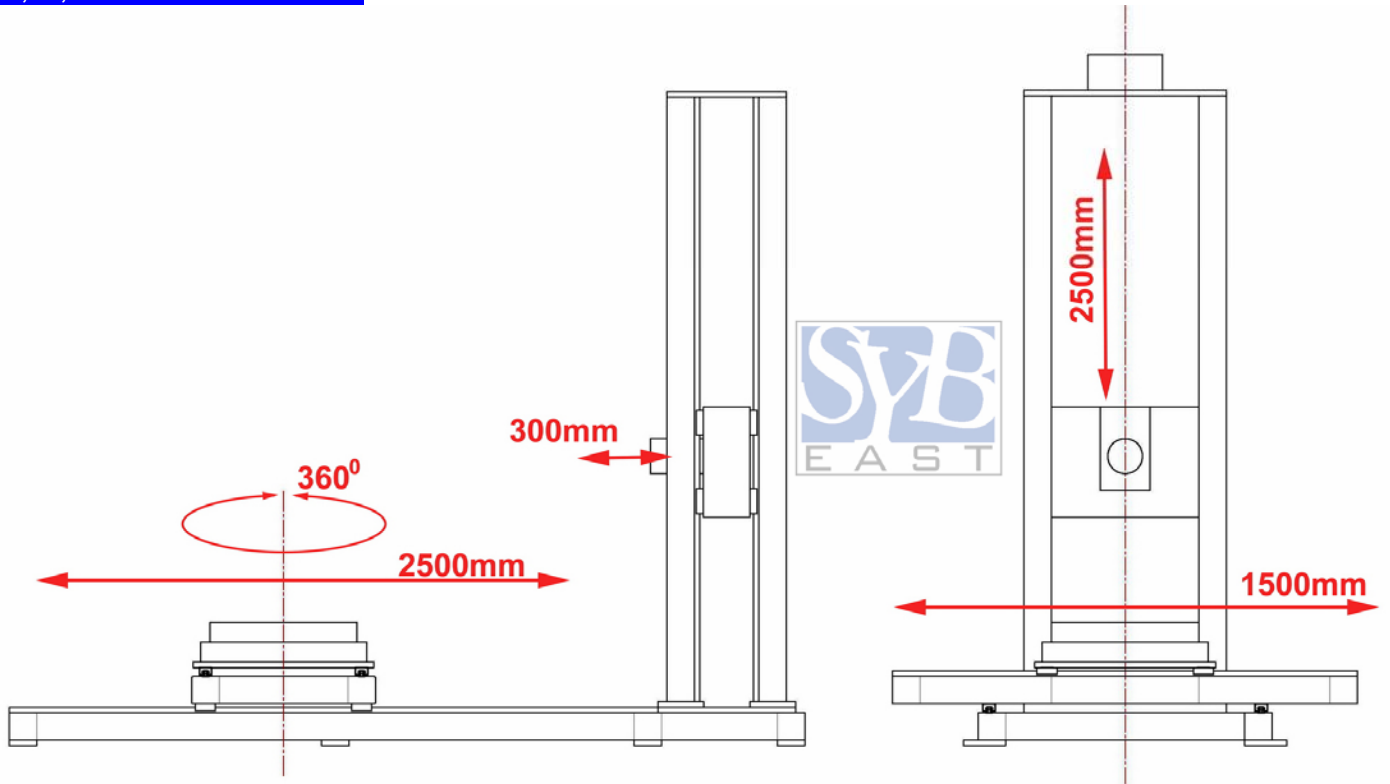

Overall Dimensions

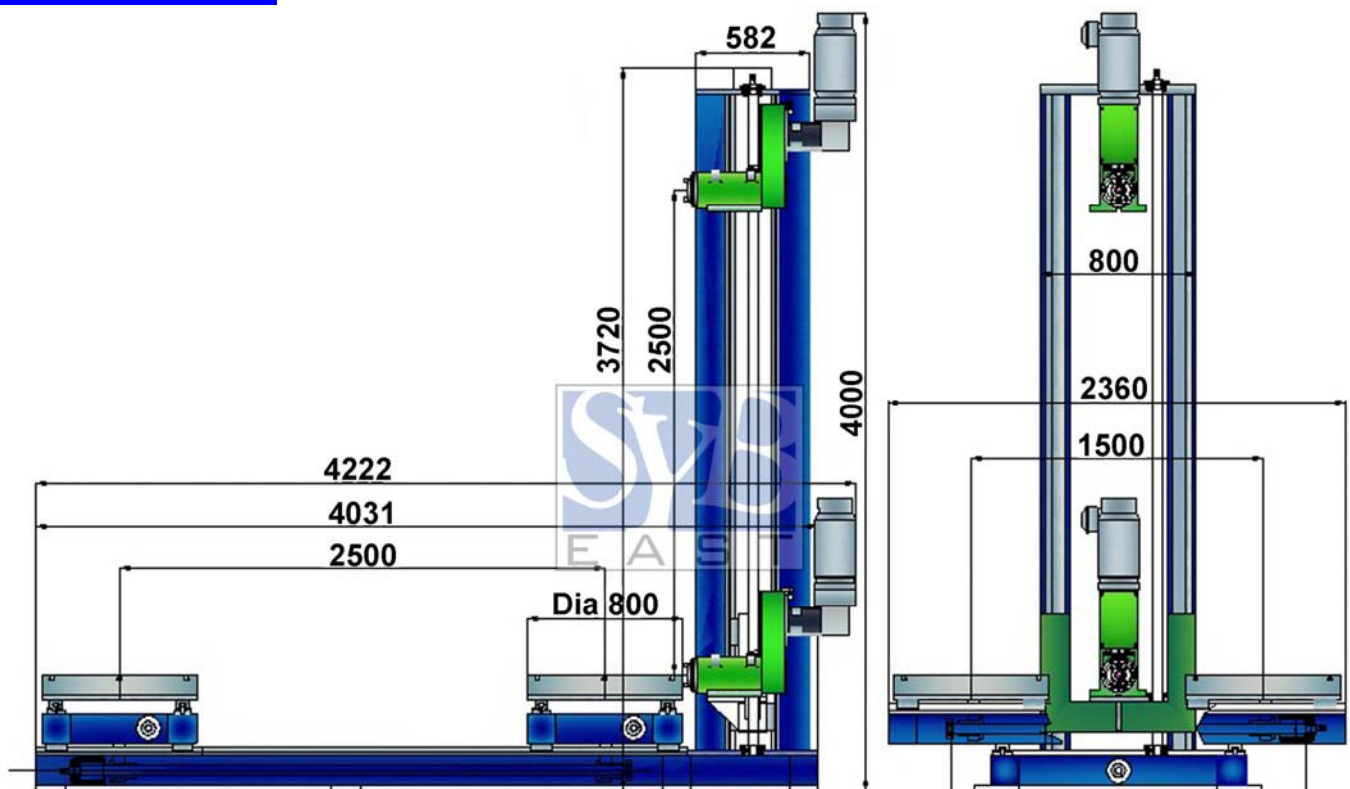



山东鑫盟制造有限公司

SYB EAST CO. LTD

Specification

HDPE & PP Manhole machining center Model: SYB 2000MM		
No	Item	Details
1.	CNC system	GSK GSK983M (three-axis 3 linkage), Four feed shafts plus and one servo-feed main shaft
		X-axis: 10N.M servo motor,
		Y-axis: 15N.M servo motor
		Z axis: 15N.M servo motor
		A-axis (Table rotation axis): 8N.M servo motor.
		Main shaft: 5.5KW servo motor, stepless speed regulation.
2.	Mechanical device	All Guides are used rolling guides and automatic lubrication system. With dust proof and ball lead screw drive/ transmission.
3	Automatic rotary working table	Hole cutting one time only without manually exchange the pipe direction.
		Table size 800 × 800mm
		Assistant working table size: \varnothing 2000mm
		Max. Clamping Dia. \varnothing 2000mm
4.	Axis	X-axis (Horizontal moving axis): Max travel distance 1500mm.
		Z axis (Facing Main shaft axis) Max travel distance of 2500mm.
		Y axis (Vertical moving axis) Max travel distance of 2500mm, with power protect device (Brake device).
5.	Main shaft	Rotating Speed: 20-1500 rpm/min
		Tool shank taper: BT40, with Pneumatic clamping / release
		Tool adjustable distance: \varnothing 50- \varnothing 650mm
6.	Guides	Provide Guides protection and automatic intermittent screw lubrication pumps for continuous lubrication.

山东鑫盟制造有限公司

SYB EAST CO. LTD

Financial Street C-609, No. 5097 Shengli East Street, Kuiwen, Weifang City, Shandong Province, China-261041.
Tel: +86.136.9636.4788, Fax: +86.536.8286690, Email: sybeastco@yahoo.com



山东鑫盟制造有限公司 SYB EAST CO. LTD

Turning Table for HDPE, PP & Plastic Manholes Welding

Model: SYB 2000RT

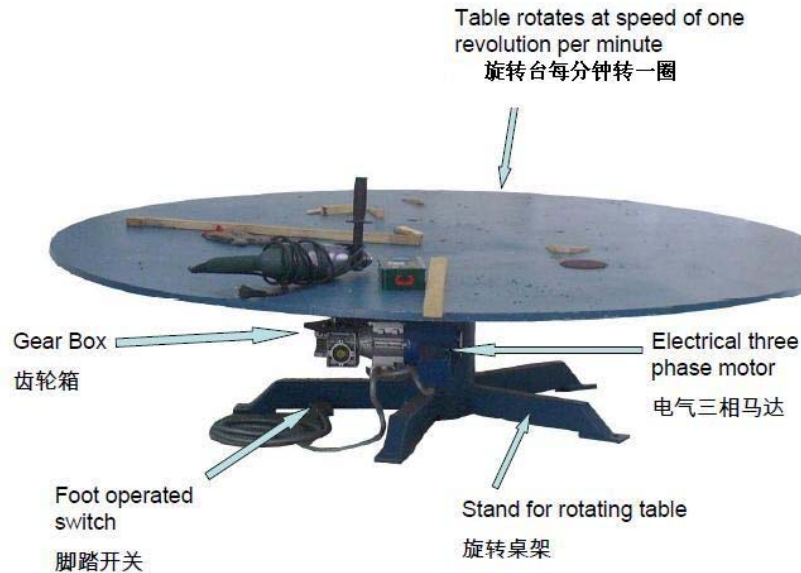

Specification

Item	Specifications
Table	Material: Carbon steel 45mm A3 Dia.: 2100mm
Motor	Variable-frequency motor, speed adjustable 0~5 rounds/ min Power: 0.37KW
Frequency Converter	Mitsubishi
Stand for table	Material: Carbon steel
Foot Operator switch	Accelerator type
Gear Box	NMRV040/090-500-YVPEJ0.37 Made in China,
Voltage	1 ϕ , 230V,50Hz ; 3 ϕ , 380V,50Hz
Max. Weight can bear	2 Tons

山东鑫盟制造有限公司 SYB EAST CO. LTD

Financial Street C-609, No. 5097 Shengli East Street, Kuiwen, Weifang City, Shandong Province, China-261041.

Tel: +86.136.9636.4788, Fax: +86.536.8286690, Email: sybeastco@yahoo.com